



U.S. Department
of Veterans Affairs

Diffusion of Innovation: Department of Veterans Affairs' pilot project to disseminate IPV programs in women's health clinics through mentoring

Maggie Czarnogorski, MD, MPH
Deputy Director, Comprehensive Women's Health
Department of Veterans Affairs

Melissa E. Dichter, PhD
Core Investigator, Center for Health Equity Research and Promotion
Department of Veterans Affairs



Increasing number of Women in Military

Demographics and History

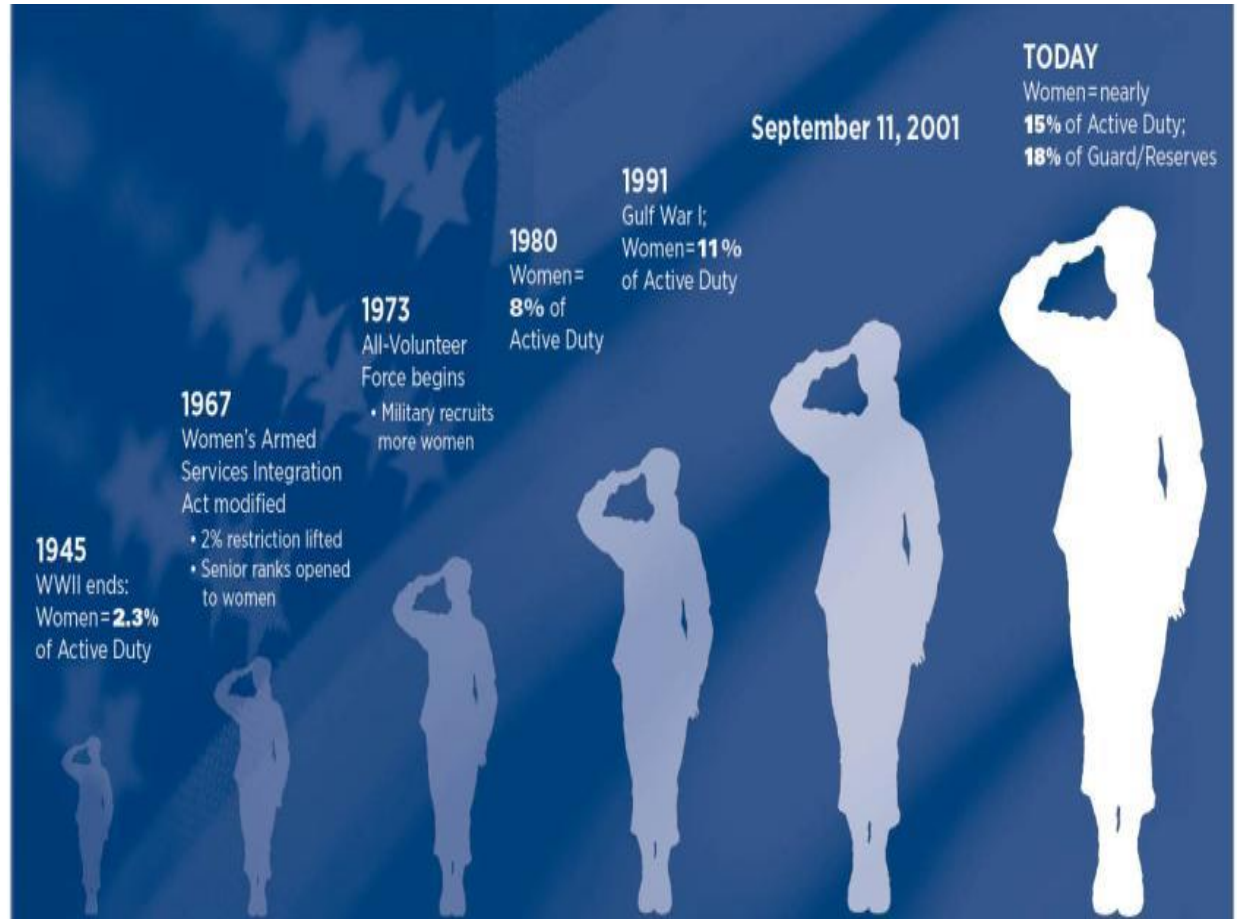

Source: America's Women Veterans: Military Service History and VA Benefits Utilization Statistics, Department of Veterans Affairs, National Center for Veterans Analysis and Statistics, Nov. 23, 2011;
http://www.va.gov/VETDATA/docs/SpecialReports/Final_Womens_Report_3_2_12_v_7.pdf



Veterans Affairs Health Care System

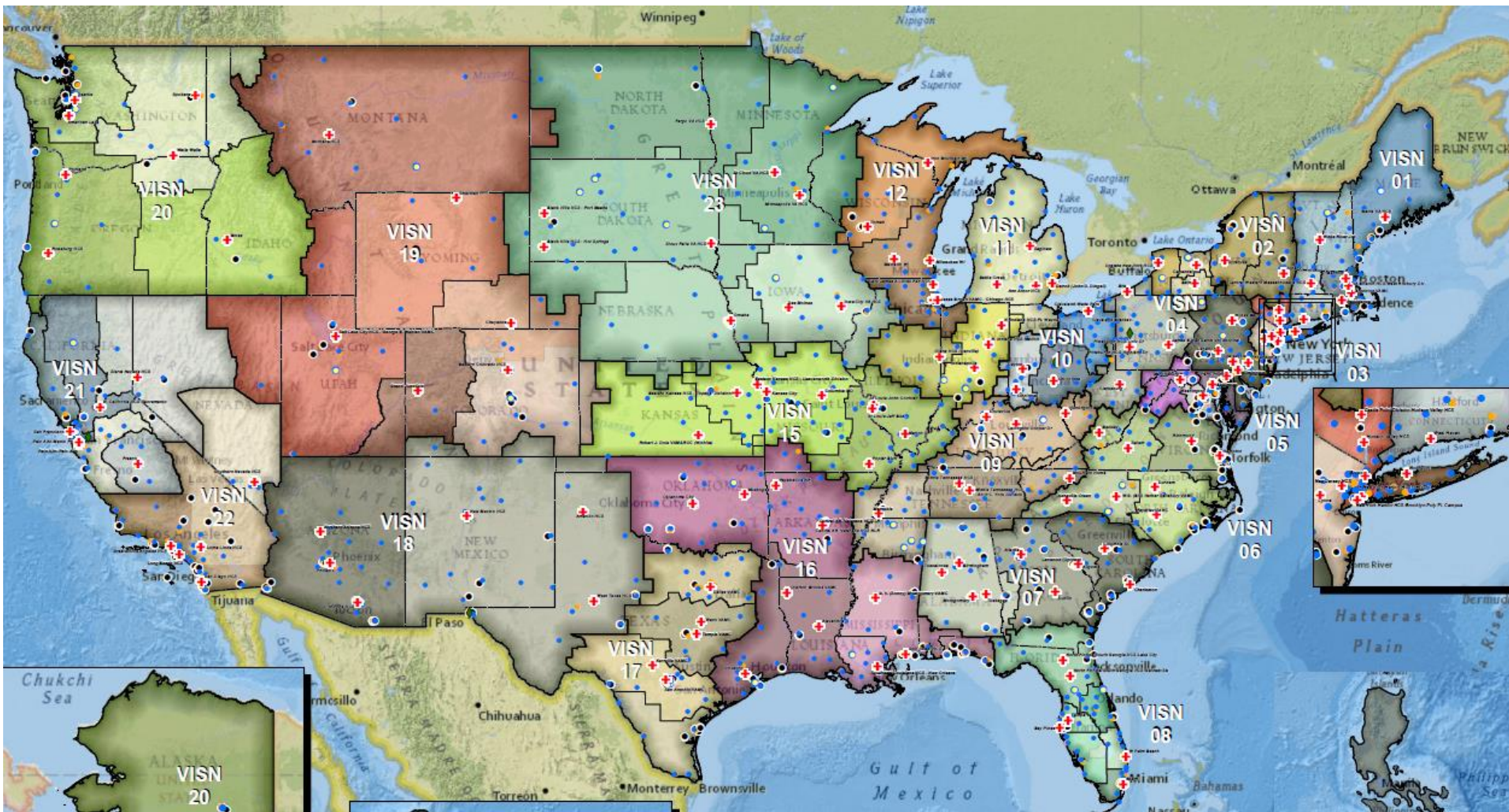



Women's Health Services

- National Women's Health Service Office
- Women's Health Program at every VA medical center
- Every VA Medical Center is expected to have a Women Veteran Program Manager and Women Veteran Medical Director

Communication Channels:

- Monthly Calls
- Monthly Webinars
- Weekly E-Newsletters
- Sharepoint Sites
- Toolkits
- Regional Meetings

If you have seen one VA, you have seen one VA....



Women's Health Mentoring Program

- Purpose: To offer facility to facility support in the implementation of strategic programs that are important to national program office.
- Topics Covered: **Intimate Partner Violence**, Lactation Support, Eating Disorders, Mindfulness/Stress Reduction, Obesity
- Each year the number of mentor sites grows, as well as the number of mentees.



Diffusion of Innovation

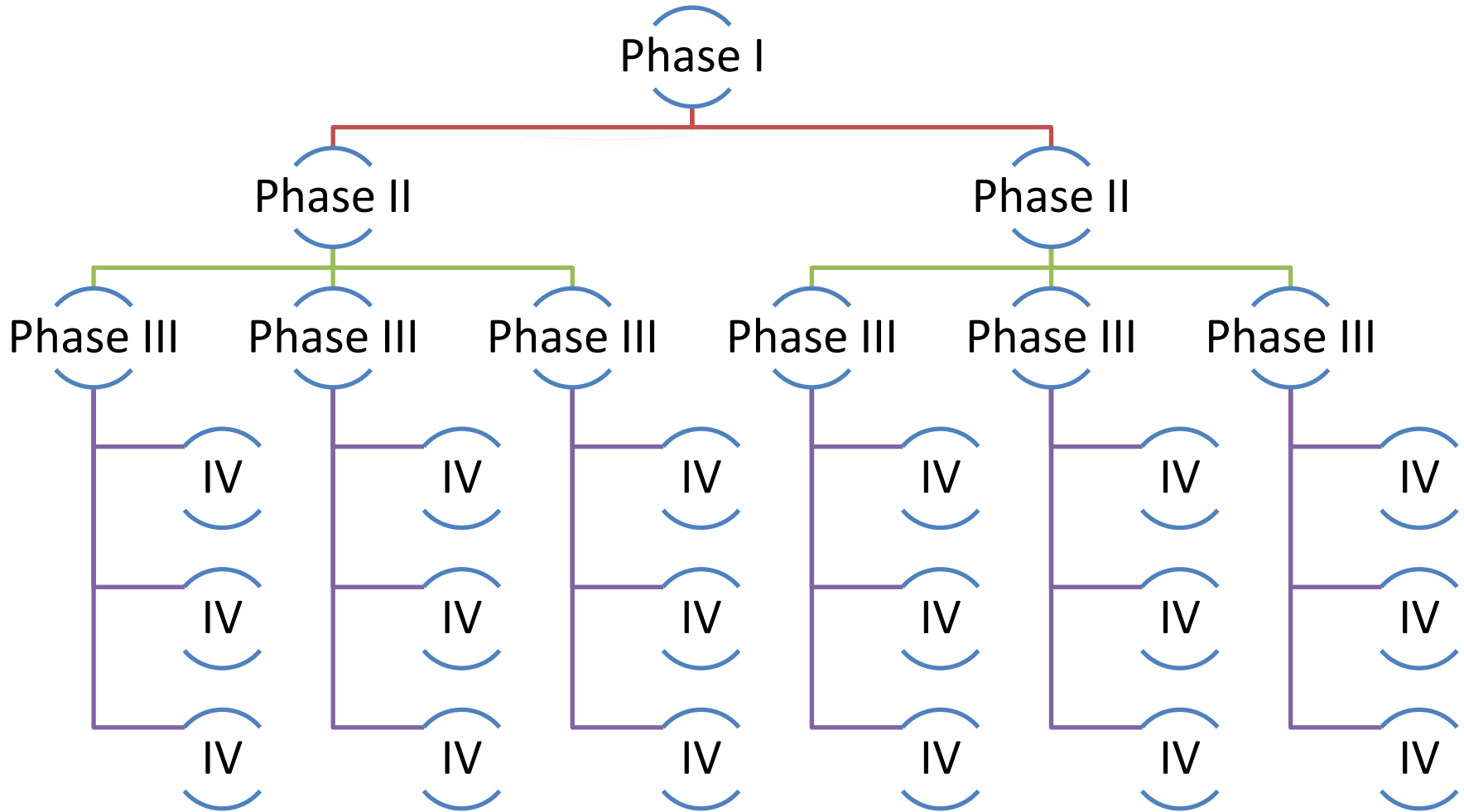



IPV and the Military

- Among active duty women...
 - 22% reported IPV during active military duty
 - 30% report adult life-time prevalence of IPV
- Higher rates of child abuse and pre-military trauma
- Primary Care: 46% report current/past IPV
- Mental health: 70% report lifetime rate of IPV
- Behavioral Risk Factor Surveillance Survey: $\frac{1}{3}$ of veteran women experience lifetime IPV compared to $< \frac{1}{4}$ non-veteran women

- Frayne et al. Medical profile of women veterans administration outpatients who report a history of sexual assault occurring while in the military. *J Womens Health Gen Based Med.* 1999;8:835-45.
- Marshall et al. Intimate partner violence among military veterans and active duty servicemen. *Clin Psychology Rev* 2005;25:862-76.
- O'Campo et al. Depression, PTSD and comorbidity related to intimate partner violence in civilian and military women. *Brief Treat Crisis Int* 2006;6:99-110.
- Sadler et al. Lifespan and repeated violence against women during military service. *J Womens Health* 2004;13:799-811.
- Sayers et al. Family problems among recently returned military veterans referred for a mental health evaluation. *J Clin Psychiatry* 2009;70:163-70.



Philadelphia VA IPV Program

Program Components

Training

- Mental/Behavioral Health, Social Work
- Primary Care/Women's Health
- Emergency Department

Screening

- Women's Health Clinic
- Emergency Department

Resources/ Support Services

- Resource Information
- Social Work IPV Specialist



Philadelphia VA IPV Program

Program Evaluation

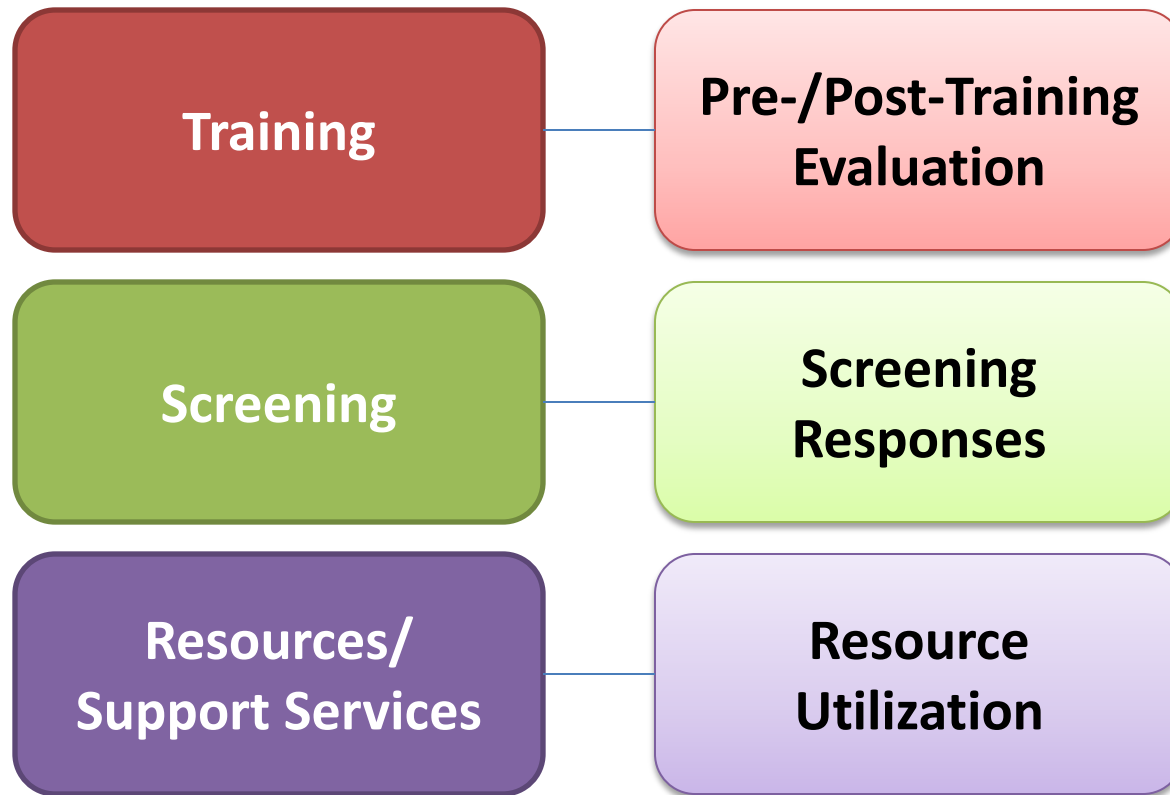



Diffusion: Working with Mentee Sites

- Communication/Process
 - Initial weekly meetings (telephone)
 - Ongoing monthly meetings (telephone)
 - As-needed consultation (e-mail or telephone)

- Sharing and Consultation
 - Updates
 - Challenges/Roadblocks/Considerations
 - Resources/Information
 - Plans/Next Steps



Diffusion: Lessons Learned

- Implementation differences: Community/Site-Specific Considerations
 - Norms
 - Events/Experiences
 - Setting characteristics
- Expanded community of practice
 - Learning from each other
 - Brainstorming together
 - Support/consultation
- Continuous refinement and feedback



Research/Practice Partnership

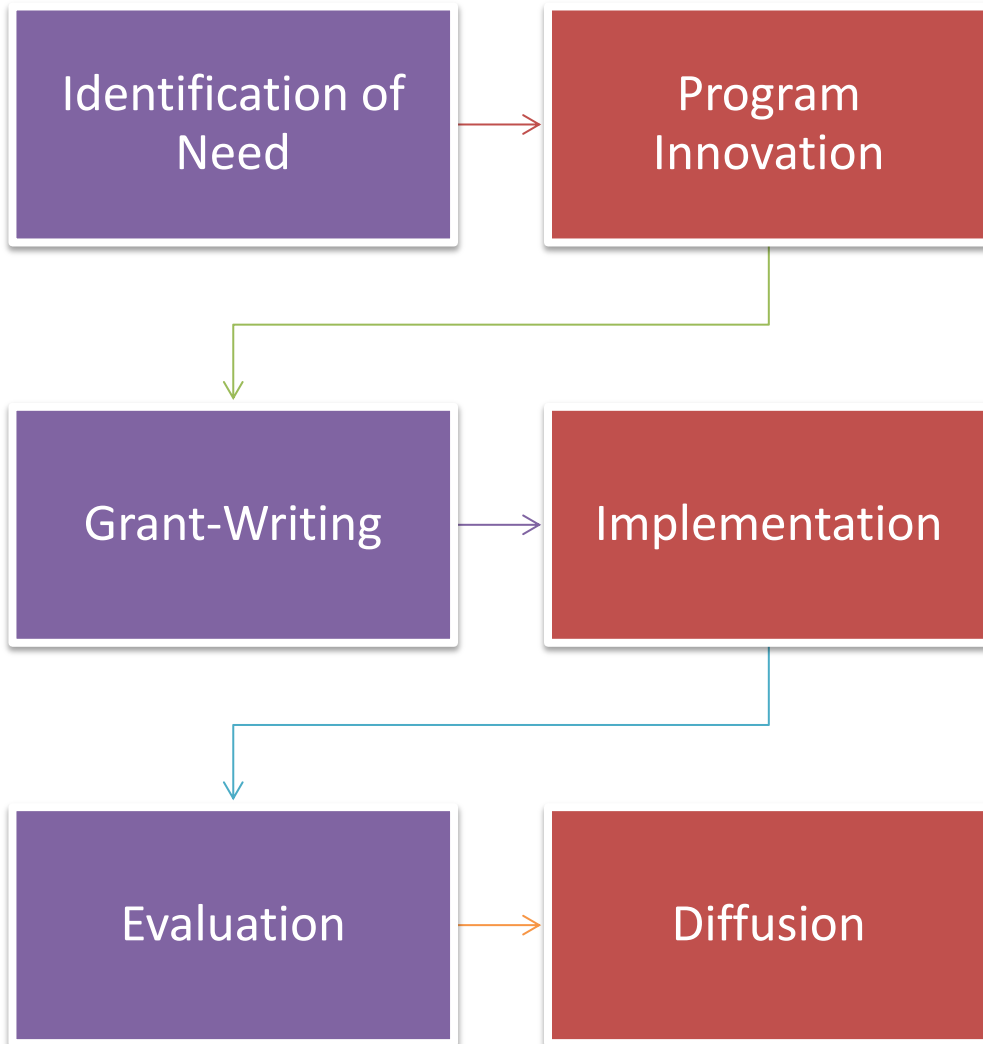



U.S. Department
of Veterans Affairs

Questions/Discussion

Maggie.Czarnogorski@va.gov

Melissa.Dichter@va.gov